

KEY FEATURES

- High performance LED surface mount bulkhead
- High transmission, low spotting opal diffuser
- TP(a) rated BS2781-0:2004
- 2 x 20 mm conduit entry points
- Tridonic LED and driver system inside
- High luminaire efficacies >125 lm/tcW
- 3 step MacAdam (SDCM)
- Long life >72,000h L80/F10
- DALI, Bluetooth and emergency options
- Integral microwave presence detector options
- 5 year warranty

DIMENSIONS

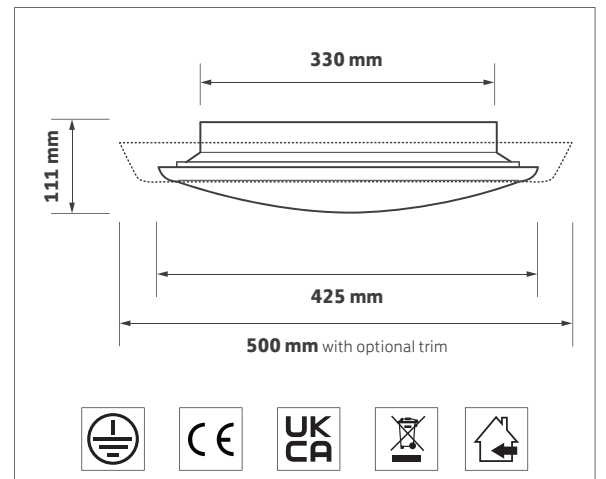

ORDERING INFORMATION

Luminaire output (lm)	Colour temp	Luminaire power (tcW)	Light source efficacy (lm/W)	Luminaire efficacy (lm/tcW)	Model ref.
1450	830	11	184	130	ABE/109.001
1525	840	11	194	136	ABE/109.002
2000	830	15	178	130	ABE/109.003
2100	840	15	188	137	ABE/109.004
2775	830	21	178	135	ABE/109.005
2925	840	21	187	142	ABE/109.006
3750	830	28	169	133	ABE/109.007
3925	840	28	178	139	ABE/109.008

OPTIONS

Options	Suffix
Control gear	/ECO, /SO, /SD, /BTC
Emergency - Integral indicator	/EM, /EMD
Product variations available	PV.

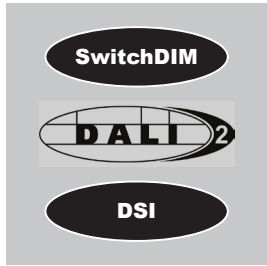

/ECO

SwitchDIM / DALI / DSI

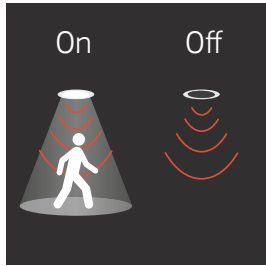

/SO

Integral motion sensor
On / off

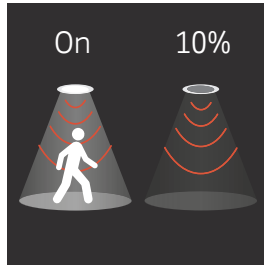

/SD

Integral motion sensor
On / 10% dim



/BTC

Casambi wireless
network inc. dimming



/EM

Emergency
Integral indicator

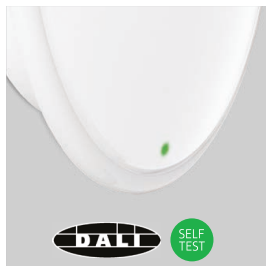

/EMD

DALI / Self-test EM
Integral indicator



DB001

Gloss white trim



DB002

Brushed steel trim



DB003

Chrome trim

PV - PRODUCT VARIATIONS



PV - Contact Sales
Black body



PV - Contact Sales
Coloured transparent
bodies



PV - Contact Sales
Prismatic lens



PV - Contact Sales
Any RAL colour trim



PV - Contact Sales
Recessing kit