



## ROBIN – WALL LUMINAIRE

Designed as an ideal bedside or reading light, the ROBIN offers an innovative and user-friendly lighting solution. This elegant surface-mounted wall light is constructed from white-coated aluminium and features modern LED technology.

Equipped with a USB connection and a smartphone holder, the spotlight can be adjusted to provide precise and ideal illumination. The second wall light source is designed for general lighting. If needed, the two light sources within the luminaire, separated by the built-in switch, can be operated independently.

### FEATURES

- 160 mm x W 280 mm
- Surface/wall installation
- Left-hand and right-hand versions
- 3000K
- Adjustable spotlight tilt
- Smartphone holder
- Finish in white or black
- CRI90
- Robust aluminium material
- Plug-and-play wiring for quick installation
- IP20 ingress protection as standard
- 5 year warranty



## SPECIFICATION

Colour Temperature CCT	3000K
Power	15W
Luminous Flux	770 lm
Efficacy	Up to 51 lm/W
CRI	>90
Controls	Fixed Output
Beam Angle	110°
Finish	White   Black
Dimensions	H 160 mm x W 280 mm x D 70 mm
Option	Left   Right
Frequency	50/50Hz
Operating Voltage	110-240 V AC
Adjustable	Adjustable spotlight tilt
Material	Aluminium
Installation	Surface/wall
Ingress Protection	IP20
Weight	1.5 kg
Lifetime	36,000hrs L70B50
Operating Temperature	-10°C ~45°C
Conformity	No UV or IR Emissions, UKCA, Class I, RoHs
Warranty	5 Years

## DIMENSIONS

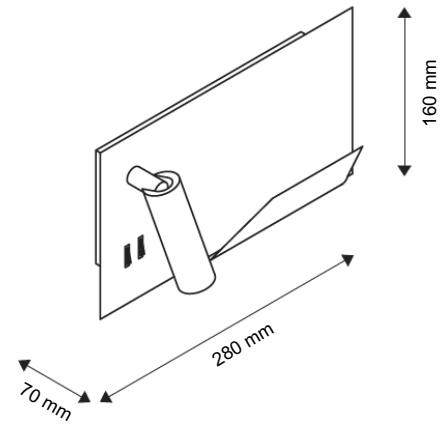

## PRODUCT ORDER CODE

EXAMPLE: ROBIN-S153LFB

PREFIX	INSTALLATION	POWER	CCT	OPTIOM	DRIVER	FINISH - REFLECTOR
<b>ROBIN -</b>	<b>S</b> surface/wall	<b>15</b> 15W	<b>3</b> 3000K	<b>L</b> left  <b>R</b> right	<b>F</b> fixed output	<b>W</b> white  <b>B</b> black