

## ALTAN – RECESSED DOWNLIGHT

The ALTAN is a high-performance surface mounted luminaire with a  $\text{\O}200$  mm diameter and deep design. It seamlessly integrates into any space and provides efficient lighting in 3000K and 4000K variants.



### FEATURES

- $\text{\O}200$  mm
- Surface mounted
- 3000K and 4000K
- Efficacy up to 91 lm/W
- $60^\circ$  satin reflector as standard
- Alternative reflector options available
- CRI80
- UGR <19
- Robust aluminium material
- Compact driver
- DALI dimming options
- Plug-and-play wiring for quick installation
- IP20 ingress protection
- 5 year warranty



## SPECIFICATION

Colour Temperature CCT	3000K   4000K
Power	14W   24W   34W   46W
Luminous Flux	1200 - 3800 lm
Efficacy	up to 91 lm/W
CRI	80
Controls	Fixed Output   DALI   1-10V
Beam Angle	60° Standard   40°   50°
UGR	<19
Finish	White   Grey   Black   RAL
Dimensions	Ø200 mm x H 240 mm
Operating Voltage	220-240V 50-60Hz
Material	Aluminium
Installation	Surface
Ingress Protection	IP20
Lifetime	50,000hrs
Weight	3 kg
Operating Temperature	-25°C ~35°C
Conformity	No UV or IR Emissions, UKCA
Warranty	5 Years

## DIMENSIONS

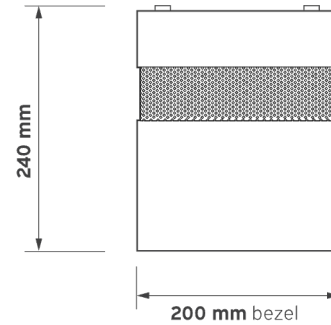

## PHOTOMETRY

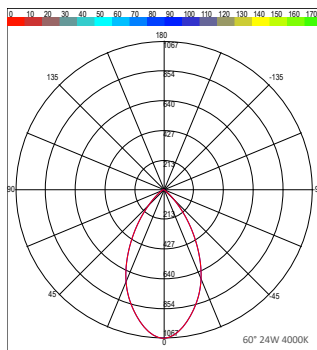

PRODUCT ORDER CODE

EXAMPLE: ALTAN-S14360WD

PREFIX	INSTALLATION	POWER	CCT	BEAM ANGLE	FINISH	DRIVER	EMERGENCY
ALTAN -	S surface	<b>14</b> 14W	<b>3</b> 3000K	<b>60</b> 60° satin	<b>W</b> white	<b>F</b> fixed output	<b>SE</b> standard emergency
		<b>24</b> 24W	<b>4</b> 4000K	<b>40</b> 40° specular	<b>B</b> black	<b>D</b> DALI	<b>DE</b> DALI emergency
		<b>34</b> 34W		<b>50</b> 50° multifaceted	<b>G</b> grey	<b>10</b> 1-10V	
		<b>46</b> 46W			<b>RAL</b> custom RAL	<b>C</b> casambi	