

### FEATURES

The SYSTEM MAGNETO range redefines the track lighting concept, offering quick installation and endless lighting configurations. The magnetic mounting allows fast and easy change over of all LED luminaires, perfect for architectural or commercial projects.

- Spotlight luminaire
- Efficacy up to 65 lm/W
- Alternate fittings without tools
- 90° adjustable tilt, 359° rotational arm
- Black or white finish
- Aluminium housing
- Compact fixed output or DALI dimming
- 48V track system
- UGR 19 compliant, CRI93, IP20



### SPECIFICATION

Luminous Flux	Up to 720 Lumens
UGR	19
Colour Temperature CCT	2700K   3000K   4000K
Power Consumption	6W   12W
CRI	93
Beam Angle	20°   40°
Efficacy	65 lm/W
Dimming	Fixed Output   DALI
Input Voltage	48V DC
Lifetime	50,000hrs
Finish	Matt White   Matt Black
Installation	Magnetic Track Mounted Pendant
Dimensions	Ø34 mm x 100 mm x 34 mm
Ingress Protection	IP20
Operating Temperature	-25°C ~50°C
Conformity	Thermal Management System No UV or IR Emissions, UKCA
Warranty	5 Years

### DIMENSIONS

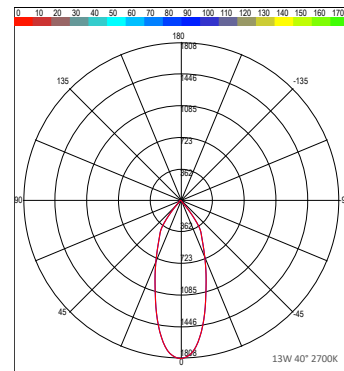
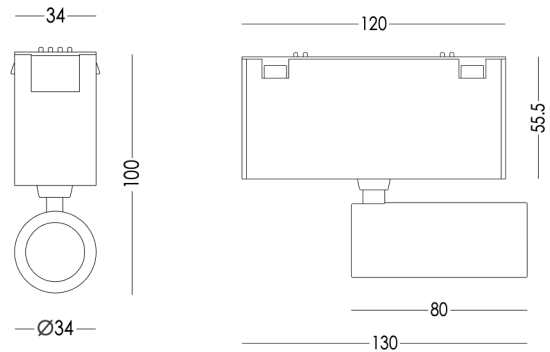

### PRODUCT ORDER CODE

EXAMPLE: MAG-SPOT35/12W/20/4K/DALI/BL

PREFIX	WATTAGE	BEAM ANGLE	CCT	DRIVER	FINISH
MAG-SPOT35	6W	20 20° beam angle	27K 2700K	FO fixed output	WH matt white
	12W	40 40° beam angle	3K 3000K	DALI DALI dimming	BL matt black
				4K 4000K	

