

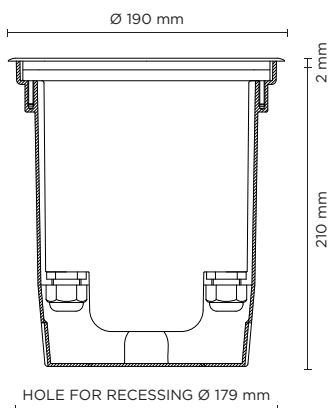

HYDROFLOOR MEDIUM COB

Ground-recessed luminaire in round shape for outdoor installation, phospho-chromatised and polyester powder coated die-cast copper-free aluminium body and stainless steel AISI 304 frame, tempered safety glass, moulded silicone gasket. Symmetrical light distribution with adjustable optics. Built-in LED driver 220-240V 50-60Hz, with 1 CREE CXB 2530 COB LED. IP67 rating.



light source	light beam options	lumen output (lm)	lumin. efficacy (lm/w)
3000°K warm-white			
cob led	20°	1.855	97.63
cob led	40°	1.802	94.84
4000°K neutral-white			
cob led	20°	1.999	105.21
cob led	40°	1.923	101.21

Finish color options:

Stainless Steel (on request)

Technical features



Technical data

Wattage	19 WATT
IP Rating	IP67
IK Rating	IK10
Material	High corrosion resistance die-cast copper-free aluminium body
Trim	Stainless steel AISI 304
Coating	Polyester powder coating with phosphochromating pre-finish
Light source	Nr. 1 CREE CXB 2530 COB LED
Screws	Stainless steel
Transformer	Electronic power supply 220/240V 50/60Hz built-in
Static weight resistance	Max 5000 Kg
Gasket	Silicone rubber
Glass	Tempered
Cable gland	Double M20
Adjustable	+/- 15 degrees
Power cable	1 mt. neoprene power cable included
Gross weight	4,00 Kg
Included	Polypropilene recessing box included

