

FEATURES

KOALA is a IP rated and impact resistance spotlight, ideal for highlighting architecture and external areas.

- Efficacy up to 80 lm/W
- Beam Angle 46°
- Die-cast aluminium module
- Tempered glass
- Corrosion and salt water resistant coating
- CRI90
- IP65
- IK08



SPECIFICATION

Luminous Flux	1195 Lumens
Colour Temperature CCT	3000K 4000K
Power Consumption	15W
CRI	90
Efficacy	80 lm/W
Dimming	Fixed Output 1-10V DALI
Operating Voltage	220 – 240V
Lifetime	50,000hrs
Finish	Grey RAL9006
Installation	Surface Wall
Dimensions	L 107 mm x W 127 mm x H 180 mm Ø114 mm
Ingress Protection	IP65
Impact Resistance	IK08
Weight	0.7 kg
Diffuser Material	Tempered Glass
Module Material	Die-cast Aluminium Corrosion/Salt Water Resistant
Operating Temperature	-25°C ~50°C
Conformity	Thermal Management System No UV or IR Emissions, EN60529-1 UKCA, CLASS I
Warranty	5 Years

DIMENSIONS

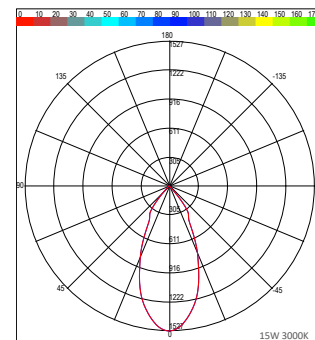
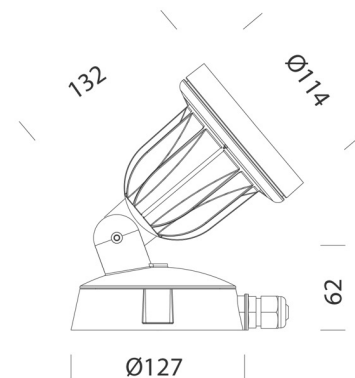

PRODUCT ORDER CODE

EXAMPLE: KOALA/15W/3K/DALI/G

PREFIX	WATTAGE	CCT	DRIVER	FINISH
KOALA	15W	3K 3000K 4K 4000K	FO fixed output 10 1-10V dimming DALI DALI dimming	G grey RAL9006